

Tate Grid

Aluminum Structural Grid System for Data Centers

Imperial Edition



Tate[®]



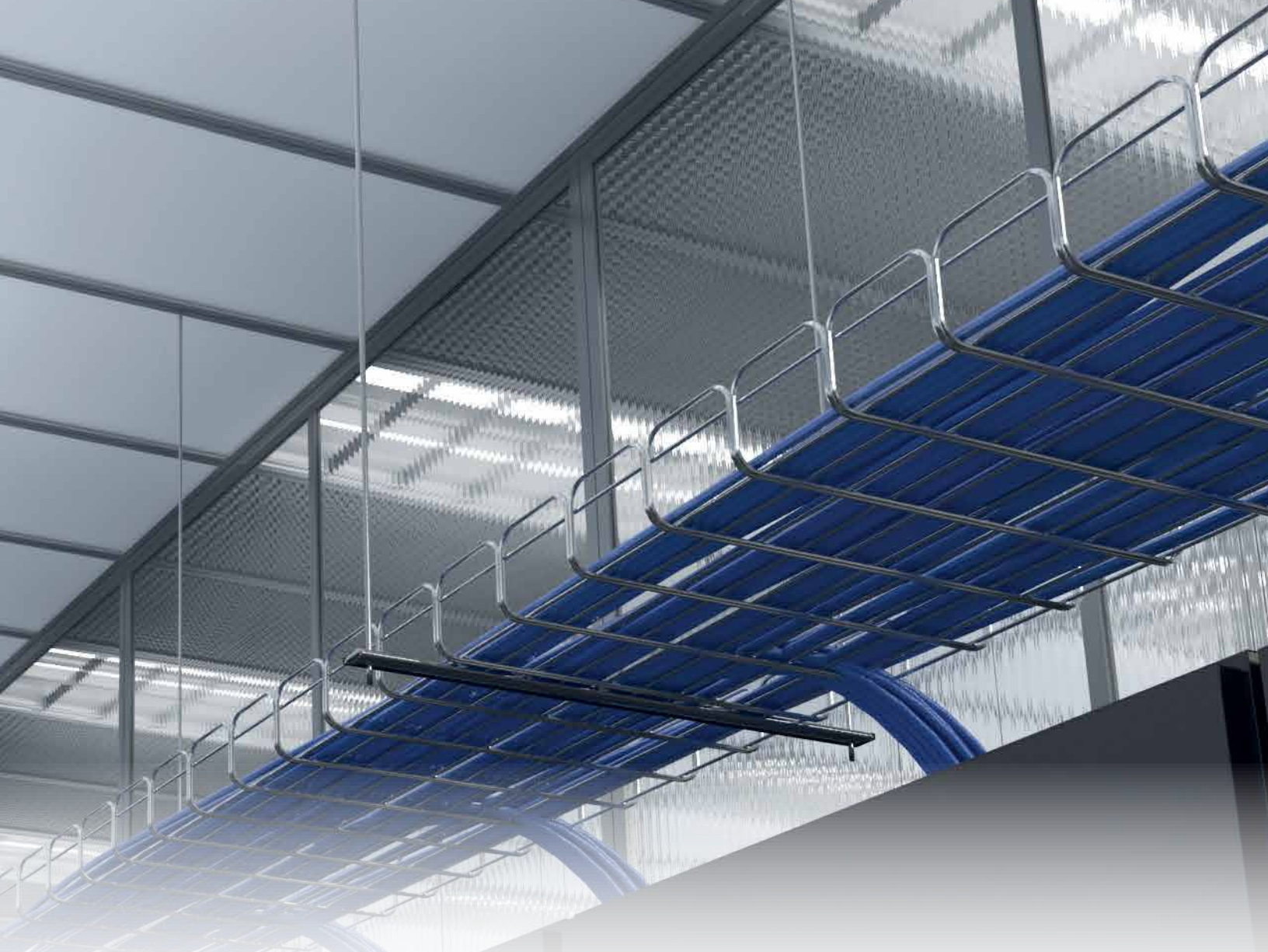

Tate Grid

Aluminum Structural Grid System for Data Centers

Tate Grid is the ideal solution for any application where large heavy items need to be suspended within a building. Replacing custom-built on-site structural support systems, such as Unistrut, with Tate Grid can offer many advantages. A structural ceiling allows you to design and specify the support solution in advance and, best of all, it's less expensive and faster to install.

Benefits of Tate Grid:

- Faster and easier to install than other grid systems
- Grid member center-to-center spacing can be selected to accommodate your specific project needs
- Eliminates the need for multiple trades on-site
- Experienced data center product manufacturer and contracting teams

Leverage our Experience

Tate offers over 50 years in data center support to your project. Our extensive dealer network of experienced contractors can rapidly support all the needs of your project including the structural ceiling, raised floor, and containment solutions.

Tate Offers:

- Application engineering team
- Skilled installation labor
- Single source to speed construction

Tate Grid

An Innovative Approach to Structural Support Systems



Tate Grid Method

Tate Grid, Tate's latest innovative data center product, allows your application to combine its structural grid and acoustical ceiling into one cohesive and easy to install unit.

Combining these two systems allows for both initial cost savings and improved installation flexibility now and in the future as the needs of your application change. Additionally, by no longer needing to penetrate the acoustical ceiling, you eliminate the threat of harmful debris that can potentially damage your data center's electrical equipment.

Standard Method

For decades, the accepted method for installing acoustical and structural components in data centers was to utilize a dual ceiling structure; both a structural grid and an acoustical ceiling would be attached to the main building structure. With this approach, any heavy items that need to be supported by the structural grid must be attached by penetrating the acoustical ceiling and feeding all thread through the hole to connect to the grid above.

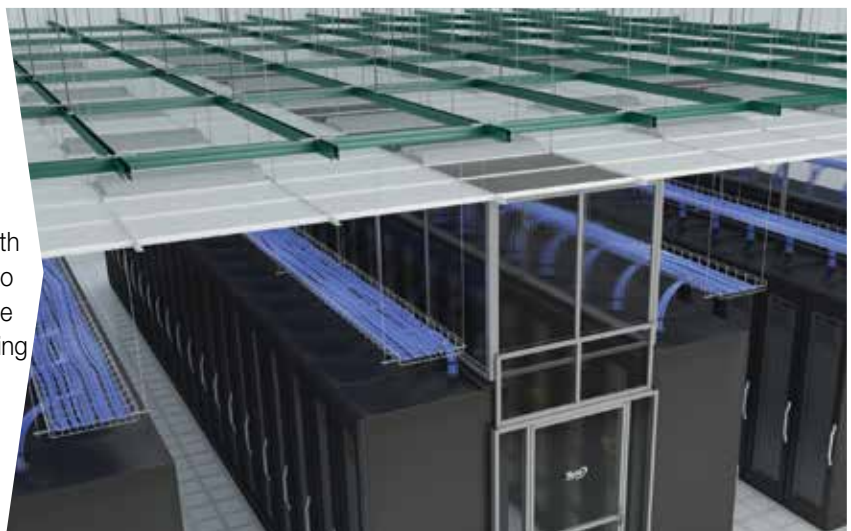

System Design

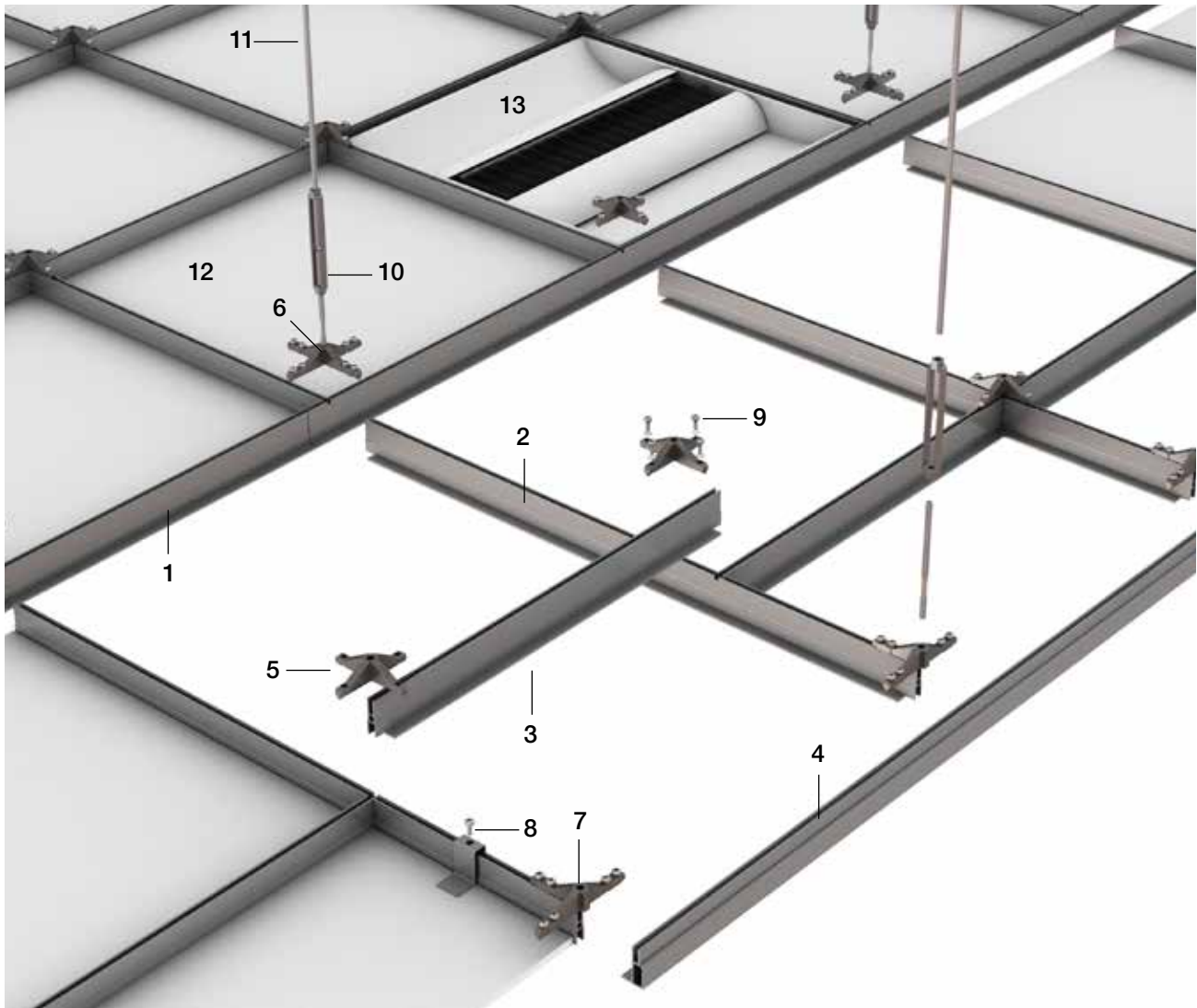

Tate Grid Component List

1. Main Runner
2. Primary Structural Tee
3. Secondary Structural Tee (optional)
4. Perimeter Extrusion (optional)
5. Field Connector
6. XL Connector
7. Perimeter Connector
8. Ceiling Tile Hold Down Clip (optional)
9. $\frac{3}{8}$ "-20 x 1- $\frac{1}{4}$ " Screws with $\frac{1}{4}$ " Lock Washer
10. $\frac{3}{8}$ "-16 Starter Rod and Turnbuckle Assembly
11. Threaded Rod Connection to Building (supplied by others)
12. Ceiling Tile (supplied by others)
13. Lighting Fixture (supplied by others)

Structural Extrusion Range

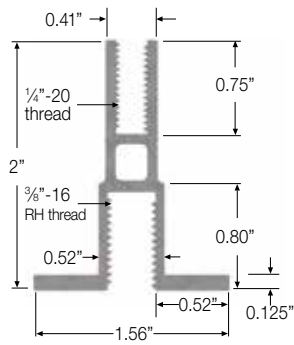

3/8"-16 Bottom Slot

- Continuous threaded 1/4"-20 top slot
- Continuous threaded 3/8"-16 bottom slot
- Utilizes standard hardware connectors and features of Tate Grid

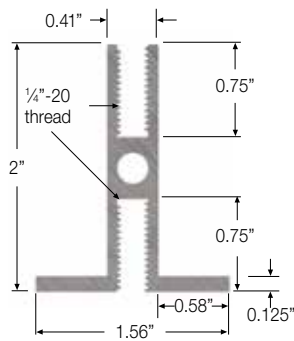

1/4"-20 Slot

- Continuous threaded 1/4"-20 slots on top and bottom
- Utilizes standard hardware connectors and features of Tate Grid

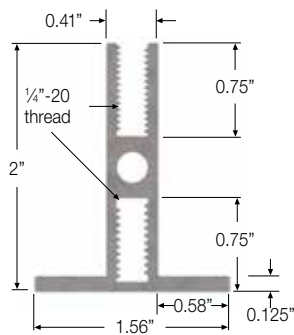

1/4"-20 Hidden Slot

- Continuous threaded 1/4"-20 slots on top and bottom
- Bottom 1/4"-20 slot is hidden and can be exposed by drilling through bottom wall cover
- Utilizes standard hardware connectors and features of Tate Grid

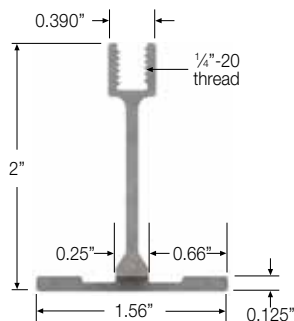

Light Structural Extrusion

- Continuous threaded 1/4"-20 top slot
- Utilizes standard hardware connectors and features of Tate Grid
- For infill applications where complete mounting flexibility across the ceiling is not required

Customized Configuration

The multiple structural extrusion options available with Tate's field grid system provides maximum flexibility to meet the specific needs of any application.

Continuous Slot

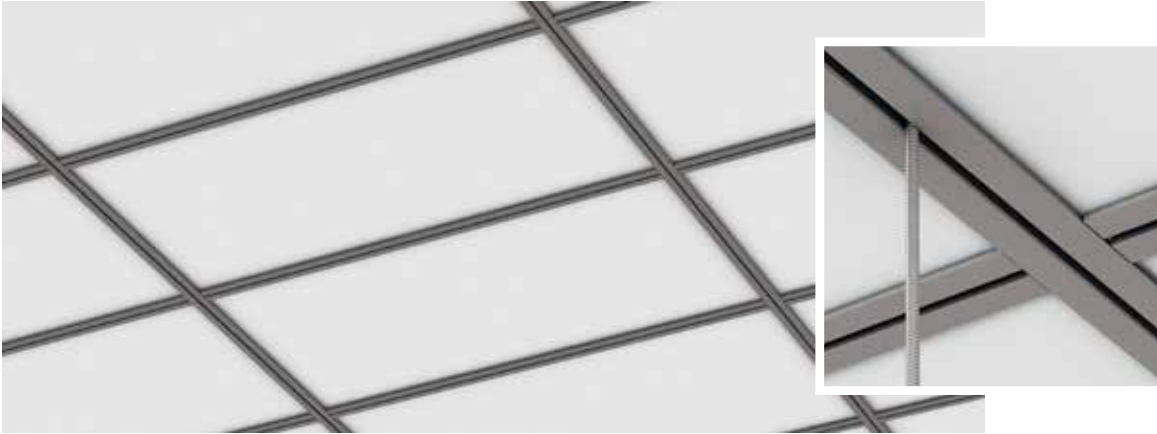

Slot and Light Duty Infill

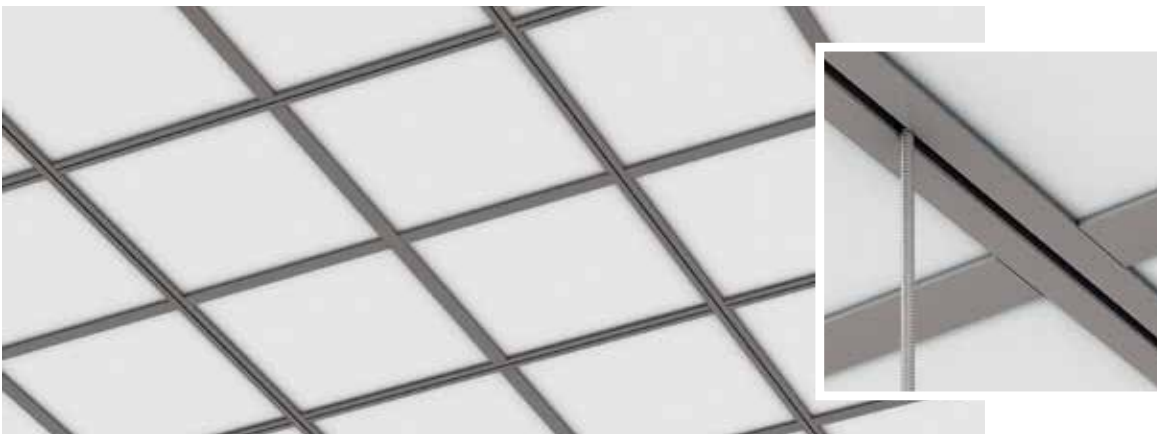

Hidden Slot

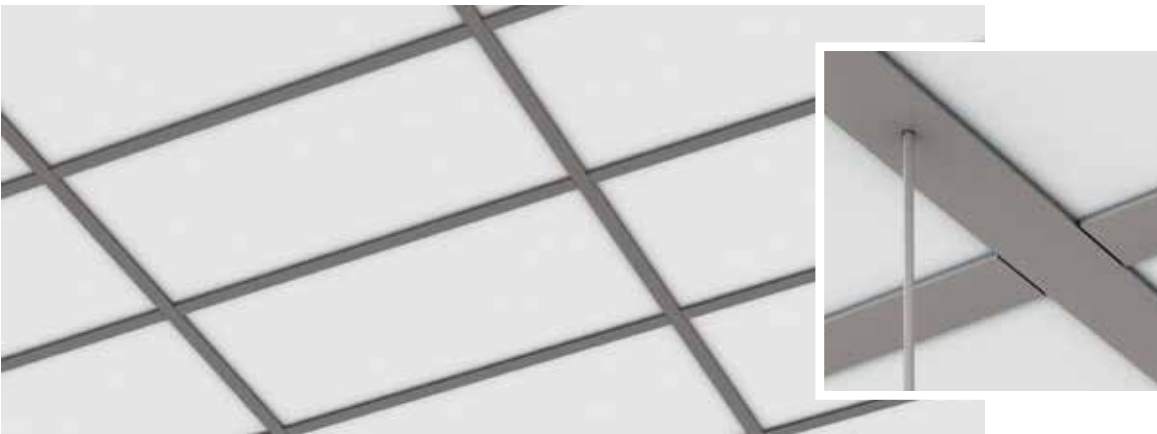

Field Details

Tate's field grid system has been engineered with alignment features that make it quick and easy to install. The Field Connectors each feature a ribbed underside that fits into the top side track of the grid. Spacing and alignment are simplified by using locating notches in the Mains and Tees which allow the rib in the connector to perfectly align the four segments of the grid. The grid is capable of supporting HVAC, light fixtures, registers, cable trays, utility racks, and other accessories.

Main Runner & Structural Tee Specifications

- Pre-engineered and factory produced aluminum structural ceiling grid with continuously threaded slot
- Grid consists of Main Runners with notches for precise location and connection of coped Structural Tees using simple four screw connectors
- Capable of supporting power modules, light fixtures, cable trays, partitions, and other accessories
- Load performance based on building connection spacing of 4 ft. on center
 - Max grid point load at midspan of 380 lbs
 - Max grid uniform load of 50 lbs/ft²
 - Safety factor of 2 for all connections
- Grid member center-to-center spacing can be selected to accommodate project-specific specifications (see page 15 for more information)
- Available in clear anodized, white, or black painted finish

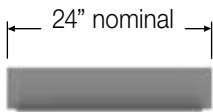

All 2' and 4' Structural Tees have coped ends which allows the grid to rest on the longer sections for stronger connections and simplified installation.

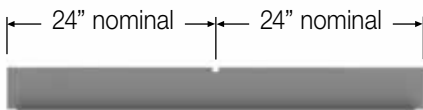

All 4' Structural Tees and Main Runners are notched every 24" on center for proper alignment and spacing of the connectors.

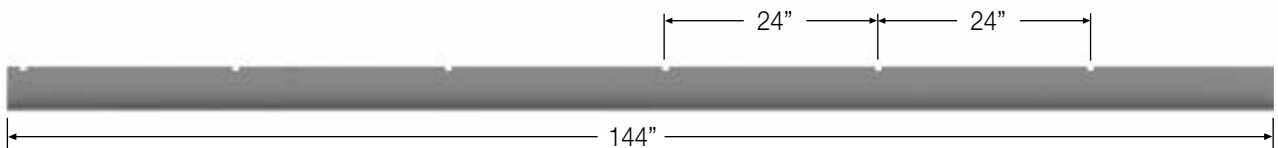

Field Connector Specifications



- Accommodates 3/8"-16 threaded turnbuckle connection
- 800 lbs point load connection to building structure
- Ribs on the bottom of the connector align with the continuous slot on the top of the grid to prevent racking
- High strength cast aluminum construction
- Corrosion resistant aluminum casting
- Attaches to grid with 4, 1/4"-20 steel screws

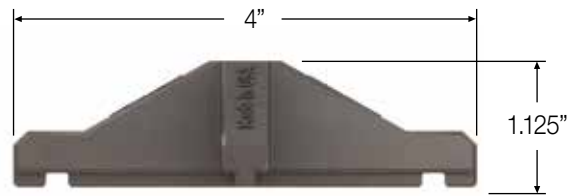

XL Connector Specifications

The XL Connector is used to splice main runners together. Like the Field Connector, it features a ribbed underside that fits into the top side track of the grid.



- Requires 3/8"-16 threaded turnbuckle connection
- 800 lbs point load connection to building structure
- Ribs on the bottom of the connector align with notches on the grid to prevent racking
- High strength cast aluminum parts
- Corrosion resistant aluminum casting
- Attaches to grid with 8, 1/4"-20 steel screws



Field Grid Assembly

While Tate Grid can be customized to meet the needs of your specific application, the following example is based on 2' x 2' grid spacing with turnbuckle connections on 4' x 4' centers.

Step 1

Install Main Runners

The Mains are equally spaced every 4'. All thread and turnbuckles are placed every 4' along the mains to connect them to the building structure. Field Connectors are used along the Mains and the connection point between two adjoining Mains require XL Connectors.

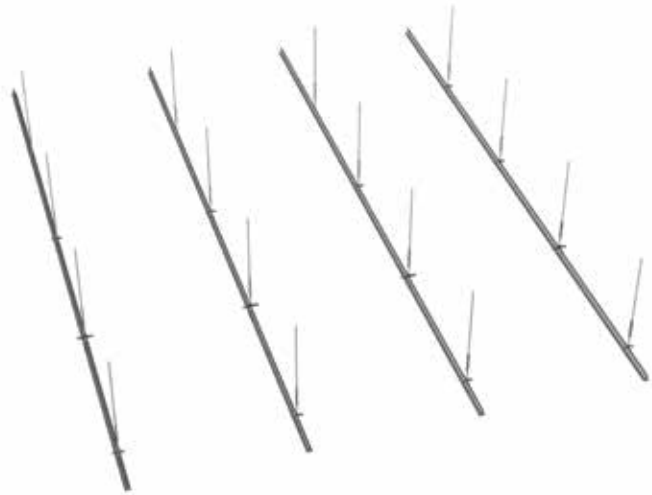

Step 2

Install 4' Structural Tees

The Structural Tees are placed every 2' along the Mains. The 4' Tee's are factory coped on each end so that they rest on top of the Mains. All connections are aligned using factory cut notches every 2' in the top edge of the Mains. The notches along the Mains provide proper location and alignment of the grid and speed up installation.



Step 3

Install 2' Structural Tees

For ceilings planning to use a 2' grid, additional 2' Structural Tees can be installed between the 4' Structural Tees. These 2' Structural Tees connect to the 4' Tees using Field Connectors. The connectors are aligned using factory cut notches in the top edge of the 4' Structural Tee.



Assembly Details

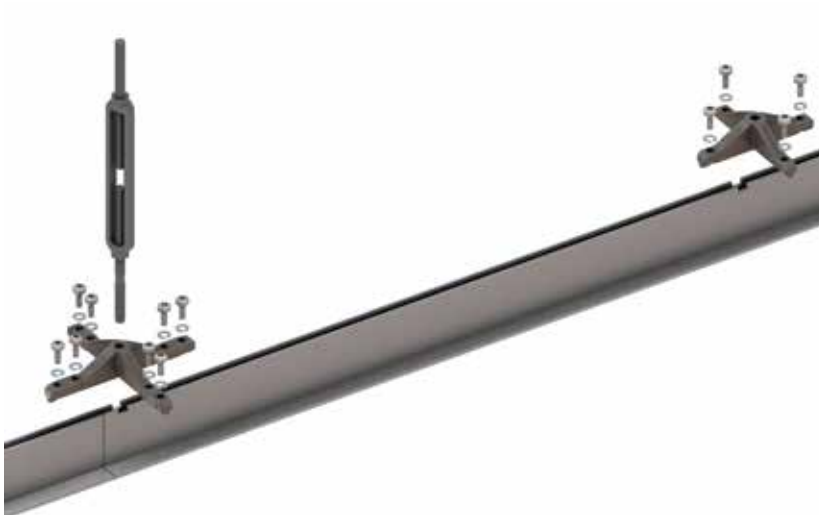

Main Runner Connections

Mains are factory notched for precise location of connectors. XL Connectors are used to splice Main Runners together and Field Connectors are used on all other connections.



4' Structural Tee Connections

All 4' Structural Tees are load bearing, providing flexibility in the location of equipment.

The close-up on the left shows factory coped Tees supported on the edge of the Main and the alignment using the factory notch in the Main Runner.

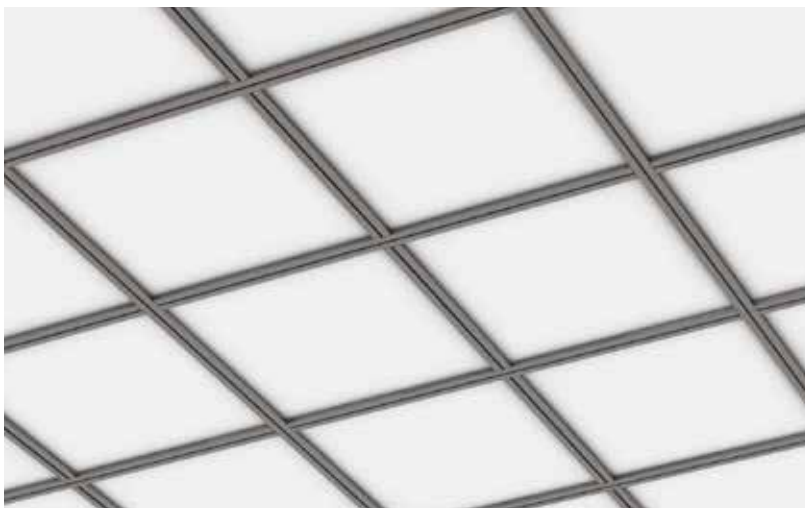

2' Structural Tee Connections

The 2' Structural Tees are installed using the same method as the longer Structural Tees. From the floor you can see that all Tees and Mains have a threaded slot for mounting equipment providing maximum flexibility.

Perimeter Details

Perimeter Connections

There are several differences between a Field Connector and a Perimeter Connector. Perimeter Connectors are primarily for installation along the walls of the space and are therefore designed to be easily cut in the field during installation. They also feature two mounted screws on each leg for additional support when 4-way connections are not an option. The bottom of the Perimeter Connector is designed with ribs to assist in the alignment of the connector on the extrusion.

Connector Specifications

- Accommodates 3/8"-16 threaded turnbuckle connection
- On site modifiable connectors for perimeter installation
- 800 lbs point load connection to building structure
- Ribs on the bottom of the connector align with the continuous slot on the top of the grid to prevent racking
- High strength cast aluminum construction
- Corrosion resistant aluminum casting
- Attaches to grid with 8, 1/4"-20 steel screws



Perimeter Angles

The Perimeter Angle provides a professional finished look along walls and columns. The angles do not have an underside track for mounting equipment, however, it will maintain the grid spacing to begin the installation.

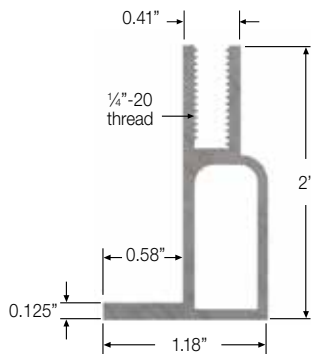

Fixed Mounting Detail

Perimeter Angles can be bolted directly to the wall with appropriate fasteners for the wall type. Note that pre-drilling is recommended and through holes are suggested for simpler light fixture or drop ceiling tile installation.



Floating Mounting Detail

The perimeter can be allowed to float with the rest of the ceiling by bolting a Wall Angle to the wall. Main Runners and Perimeter Connectors are then used so the ceiling grid can be floated up to touch the Wall Angle.



Performance Criteria

The bottom side of the structural grid is available with a 3/8"-16 or 1/4"-20 continuous threaded slot for mounting items directly to the grid. Refer to the table below for load performance details on the grid and connections.

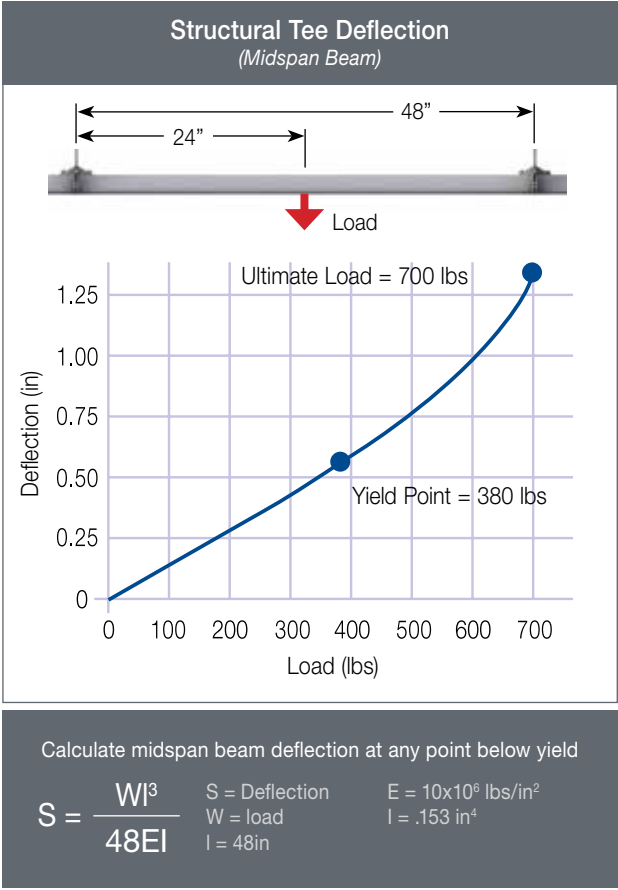

System Performance Criteria			
Hanging Method	Grid Load Performance <i>(with building connections 4'x4' on centers)</i>	Connection to Bottom Slot	Connector to Grid
Point Load (lbs)	380 lbs*	380 lbs*	800 lbs*
Uniform Load (lbs/ft ²)	50 lbs/ft ²	-	-
Ultimate Point Load (lbs)	700 lbs	760 lbs	1600 lbs

*Max point load no less than 4' apart in any direction.

Grid Spacing & Tile Sizing

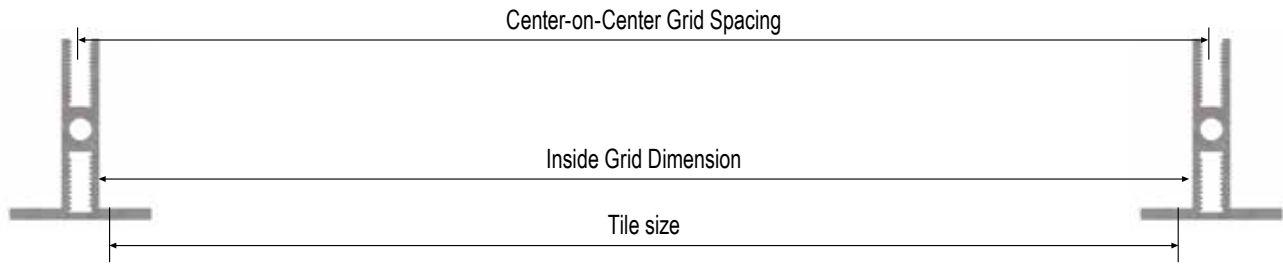

If you want the Grid Spacing to be on a 24" x 24" or 24" x 48" module size, use this table to determine tile size requirement:

Grid Profile	Grid Spacing (L x W)	Tile Size (L x W)
1/4"-20 Bottom Slot & 1/4"-20 Hidden Slot	24" x 24"	23 5/16" x 23 5/16" +/- 5/32"
	24" x 48"	23 5/16" x 47 5/16" +/- 5/32"
3/8"-16 Bottom Slot	24" x 24"	23 7/32" x 23 7/32" +/- 1/8"
	24" x 48"	23 7/32" x 47 7/32" +/- 1/8" (see example below)

Note: Maximum Tile Size = Inside Grid Dimension minus 1/8". Minimum Tile Size is based on a minimum overlap on the extrusion flange of 1/8" when the tile is shifted all the way to one side.

If you want the Grid Spacing to be on a larger module size to fit standard 24" x 24" or 24" x 48" nominal tile sizes, use this table:

Grid Profile	Grid Spacing (L x W)	Tile Size (L x W)
1/4"-20 Bottom Slot & 1/4"-20 Hidden Slot	24 13/32" x 24 13/32"	23 3/4" x 23 3/4" +/- 1/8"
	24 13/32" x 48 13/32"	23 3/4" x 47 3/4" +/- 1/8"
3/8"-16 Bottom Slot	24 1/2" x 24 1/2"	23 3/4" x 23 3/4" +/- 1/8"
	24 1/2" x 48 1/2"	23 3/4" x 47 3/4" +/- 1/8" (see example below)

Note: Maximum Tile Size = Inside Grid Dimension minus 1/8". Minimum Tile Size is based on a minimum overlap on the extrusion flange of 1/8" when the tile is shifted all the way to one side.

Sizing Based on 24" x 48" Grid Spacing

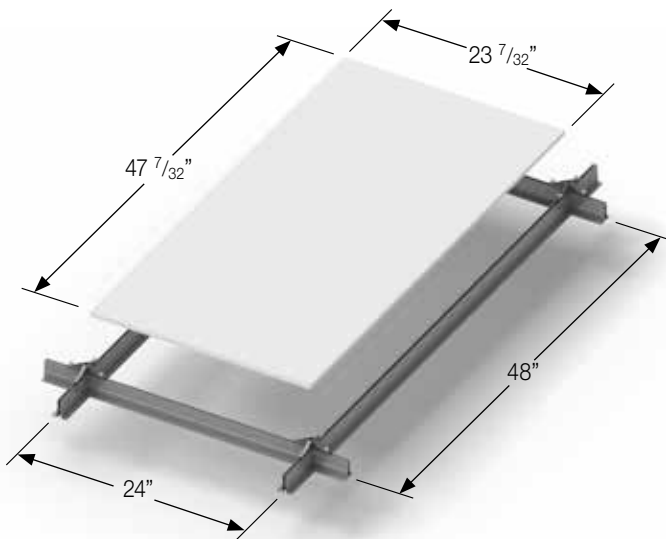

Sizing Based on 24" x 48" Nominal Tile Size

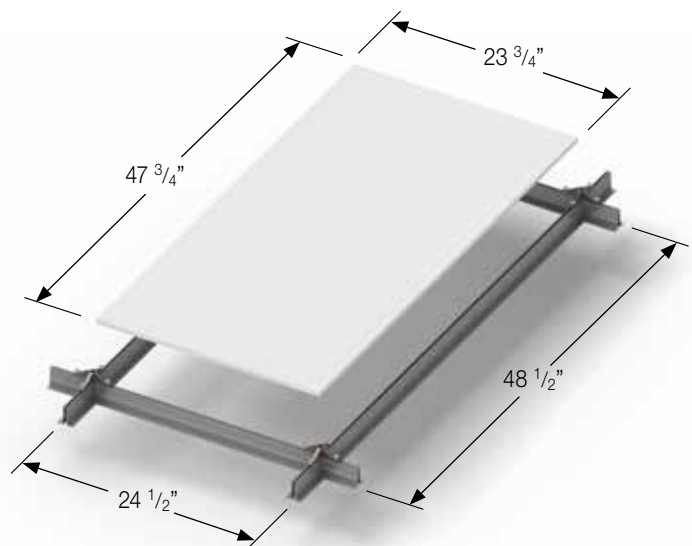

Customizable Solutions

Tate offers a level of flexibility not commonly available from other ceiling manufacturers. Our standard grid sizes are 2x2 or 2x4, however, we know that some installations require other sizes. We are happy to work with you to create a 2x5, 5x5, or any other variation of grid to fit your needs. In addition, we have the capability to create custom solutions that combine structural and non-structural components within the same grid system.

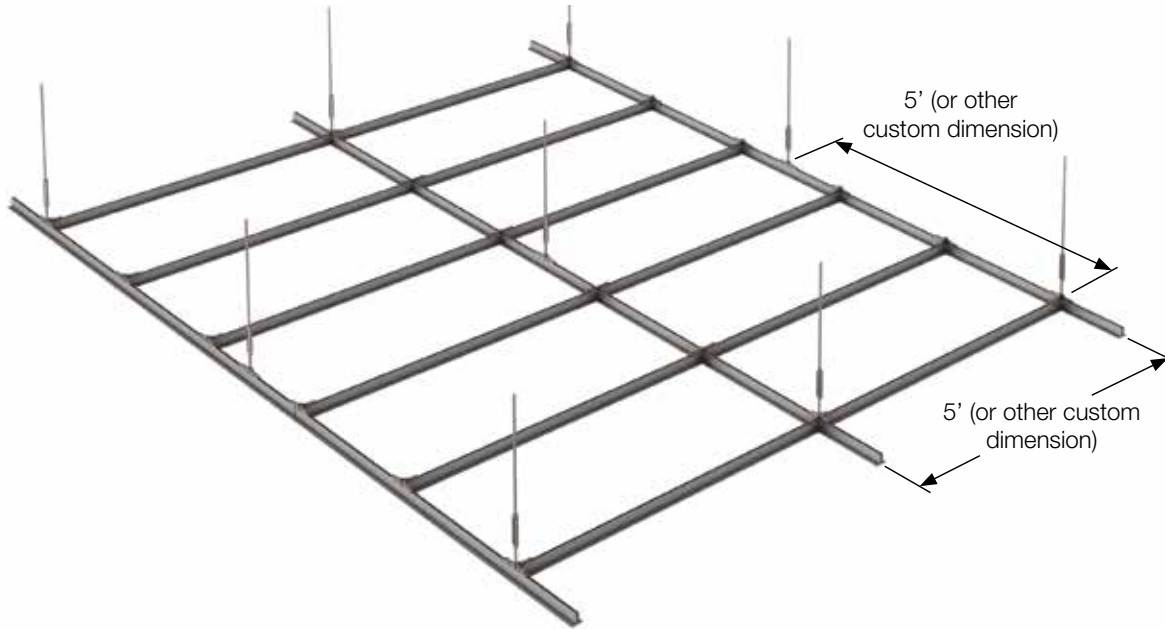

Light Structural Extrusion

Tate has developed a Light Structural Extrusion that is designed to integrate with the Main Runners and Structural Tees. This offers a customizable solution for applications that do not require complete mounting flexibility across the ceiling. The Light Structural Extrusion features a smooth underside and a threaded slot on the top for easy connection to Main Runners and Structural Tees with a Field Connector.

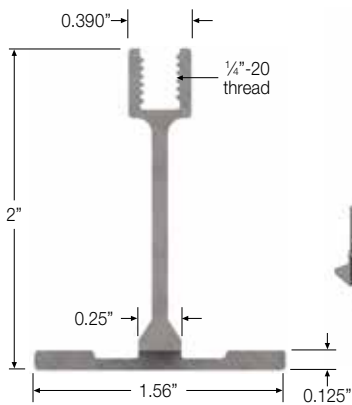

Ceiling Tile Gaskets

Gaskets can be added to the Main Runners and Structural Tees to create an air-tight dust free ceiling installation. The factory applied adhesive backed gasket is placed on the top side of the extrusion. A mounting clip can be used to keep the ceiling tiles tightly secured against the gasket.





Corporate Headquarters:

7510 Montevideo Road,
Jessup, MD 20794
Tate Hotline: 1-800-231-7788
Tel: +1 410 799 4200 Fax: +1 410 799 4207

Production Facilities:

7510 Montevideo Road,
Jessup, MD 20794
52 Springvale Road,
Red Lion, PA 17356
Tel: +1 717 244 4071 Fax: +1 717 246 3437

Canadian Sales & Support Office:

880 Equestrian Court, Oakville,
ON L6L 6L7 Canada
Tate Hotline: 1-800-231-7788
Tel: +1 905 847 0138 Fax: +1 905 847 0141

Australian Sales & Support Office:

28 Biloela Street, Villawood NSW 2163
Tel: +61 02 9728 4111 Fax: +61 02 9728 3088

Asia Sales & Support Office:

19 Cecil Street
#05-15, 5th Floor, The Quadrant
Singapore 049704
Tel: +65 6653 5358

Central and South American Sales & Support:

Tel: +1 443 995 1808

European Sales & Support:

B16 Ballymount Corporate Park,
Ballymount Avenue,
Ballymount, Dublin 12, Ireland
Tel: +353 (0) 87 1238383

Middle East Sales & Support:

Jebel Ali-Lahbab Road (E 77 Road)
Dubai Investment Park
United Arab Emirates
Tel: +971 56 199 8368

tateinc.com

A Kingspan Group Company



Tate components are proudly made in the U.S.A.